

# FTTM-8 INSTALLATION INSTRUCTIONS

For more instructions, please visit [orcahardware.com](http://orcahardware.com).

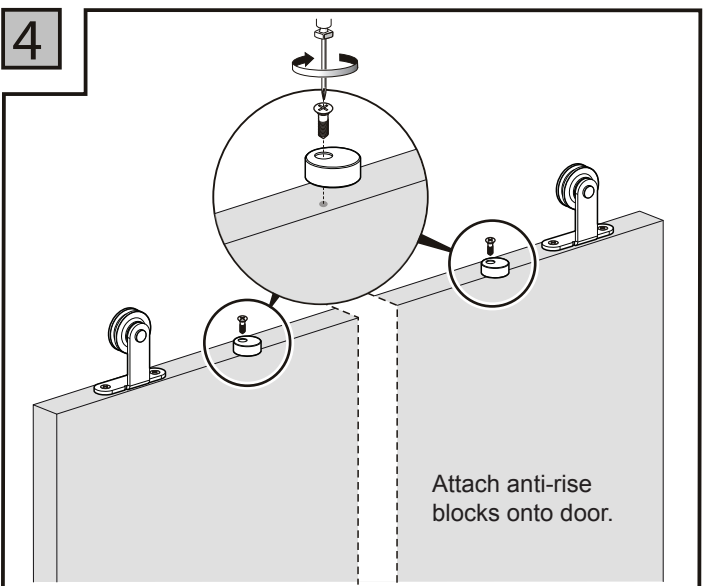

5

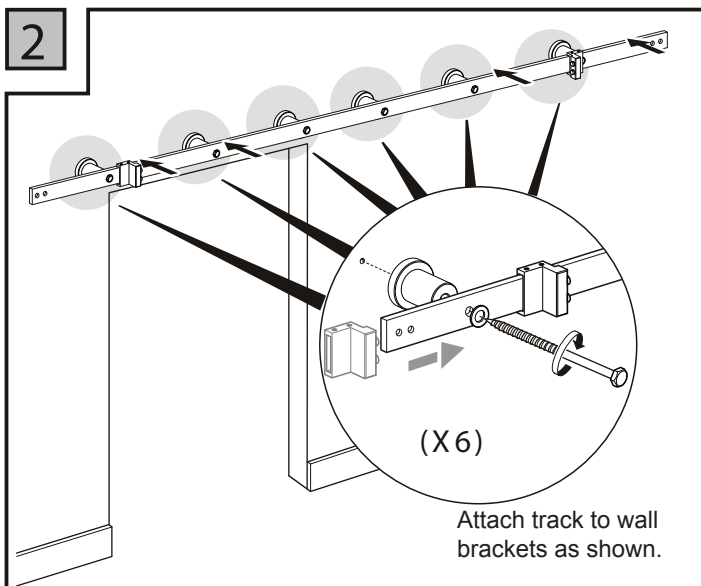
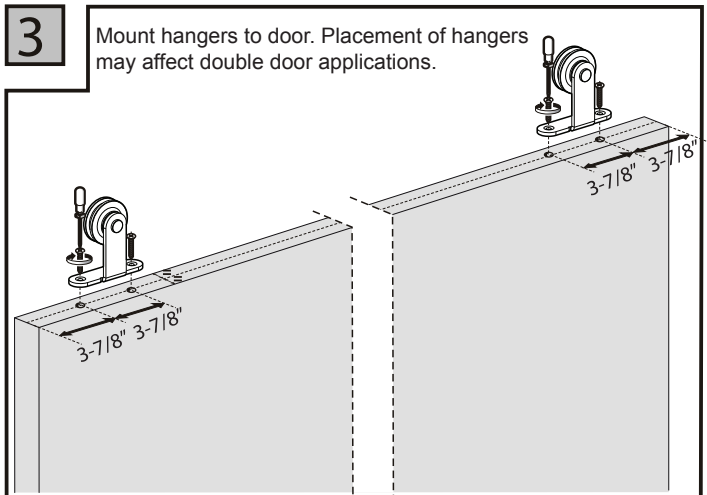
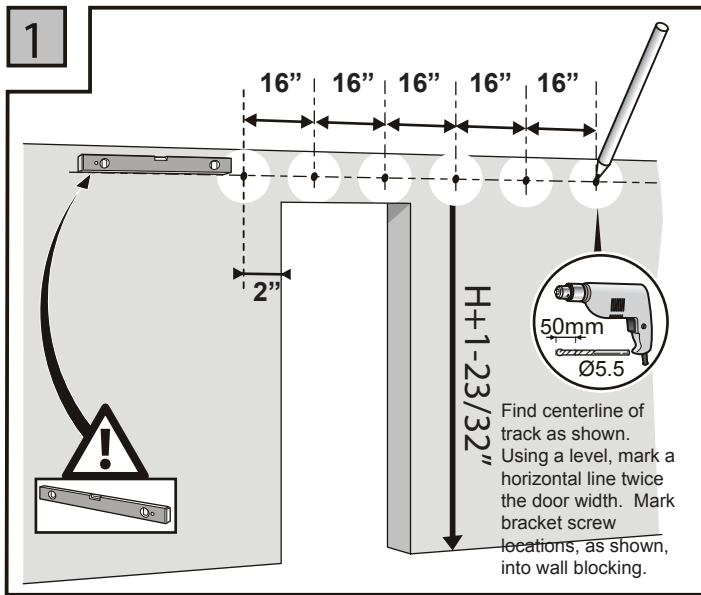
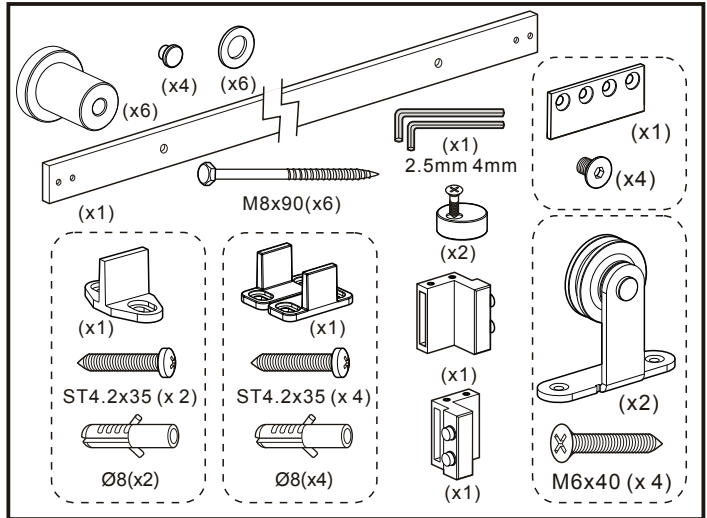
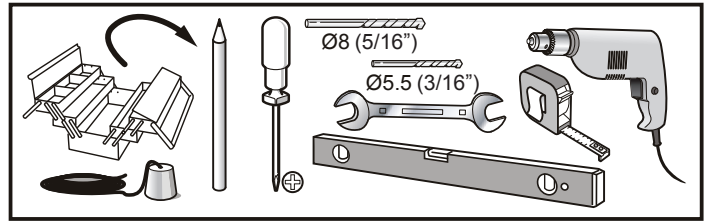
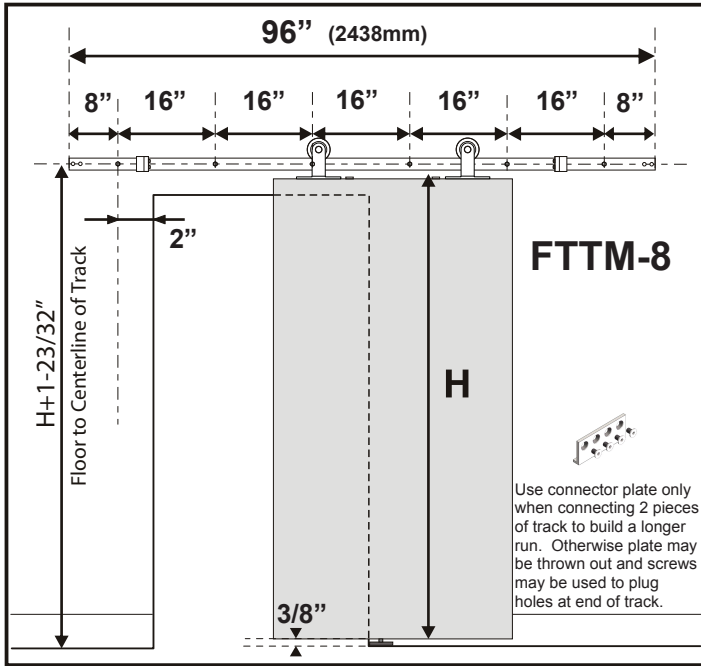
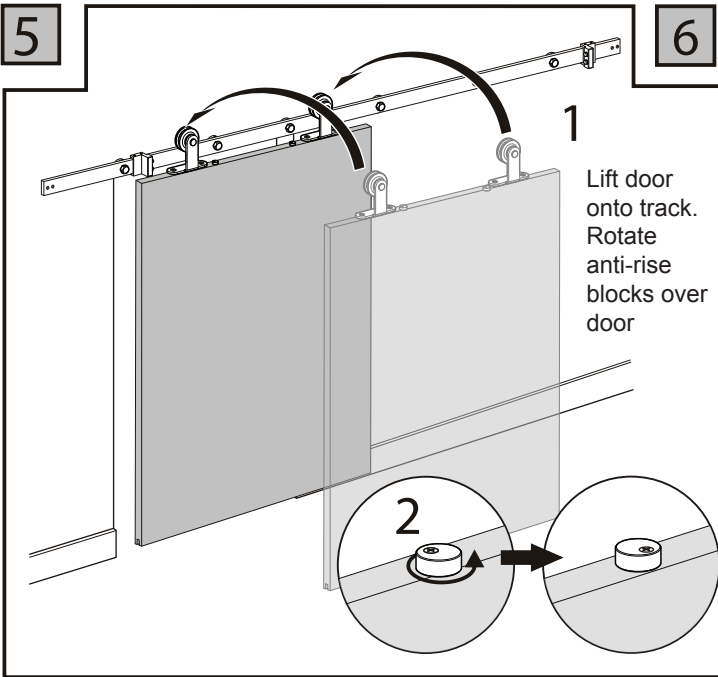

6

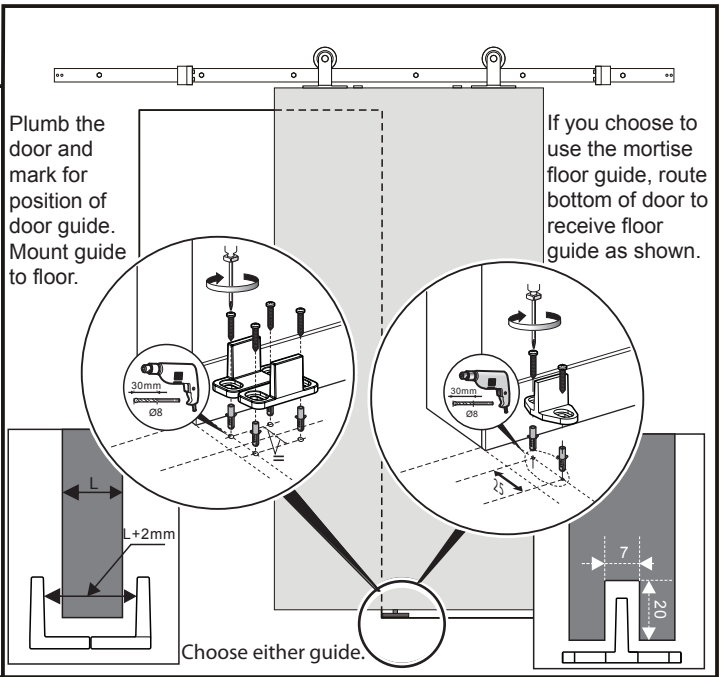

7

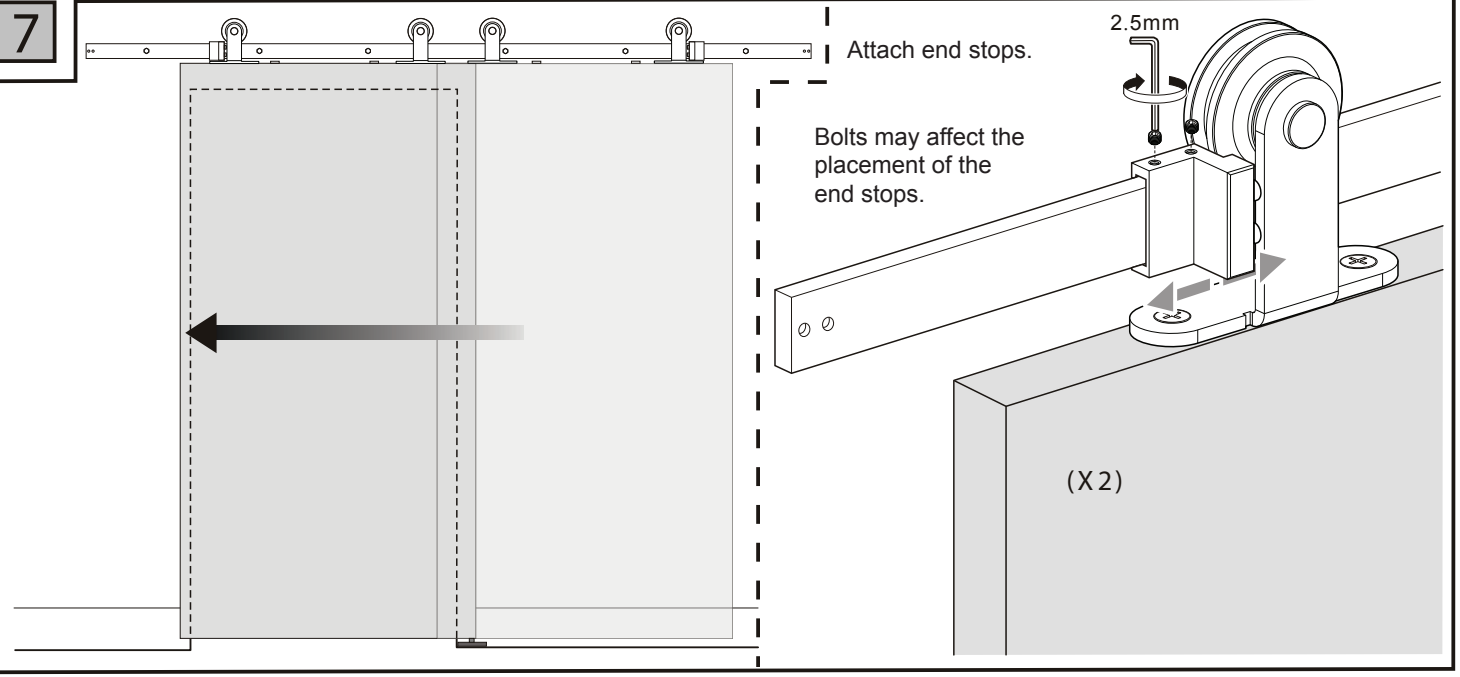

8

